

Features

- Driving DC, BLDC, PMSM motors from ~20W to ~1000W
- Programmable current source gate drivers up to 400mA gate current to drive B6-NMOS bridge
- Powerful 32 Bit Arm® Cortex®-M4¹⁾ core
- 128kB Hybrid program memory
 - 96kB ECC protected Flash
 - 32kB System ROM incl. LIN protocol and bootloader
- 8kB SRAM with ECC protection, 256 Byte EEPROM
- Current measurement by single external shunt, integrated amplifier with digital gain and offset setting and fast 12bit ADC
- Four channel PWM generator (left-/center-/right-aligned)
- High side charge pump supply for 100% duty ratio PWM
- LIN/PWM interface integrated on chip
- LIN 2.x compliant to ISO17987 and SAE-J2602-2
- User-configurable GPIOs including SPI and analog input
- Wide operating voltage range 7V – 28V
- Extended voltage range with ext. charge pump 3V..28V
- Optional oscillator input for external crystal
- AEC-Q-100 qualified
- Support for functional safety applications up to ASIL B according to ISO26262

Applications

- Electric cooling fans, HVAC fans,
- Fuel, hydraulic, oil and water pumps

General Description

The E533.06 is a powerful 3 phase BLDC motor controller for 12V automotive application. The device combines a 32bit Arm® Cortex®-M4 microcontroller, large program memory, advanced coprocessors and gate driver circuits in a small footprint package.

The embedded PWM- and ADC-accelerator units offer enhanced performance for sensor-less, single shunt motor control. This enables advanced control algorithms like FOC with all calculations and measurements executed in each PWM cycle (less than 25µs), leaving 50% free CPU load for the applications.

The large program memory offers enough space for motor control algorithms, communications and diagnostics while keeping the flexibility for additional functions or the required free memory at project start.

The E533.06 is developed according to ISO26262, based on safety requirements rated up to ASIL B.

Due to the optimized feature set and high system performance the E533.06 is the perfect solution to fulfil the demand for drive dynamics in pumps or silent operation for fans and blowers.

Ordering Information

Ordering-No.	Temp Range [T _j]	Package
E53306A78B	-40°C to +150°C	QFN48L7
E53306A99H	-40°C to +150°C	LQFP48L7EP

1) ARM® and Cortex® are the registered trademarks of ARM Limited in the EU and other countries.

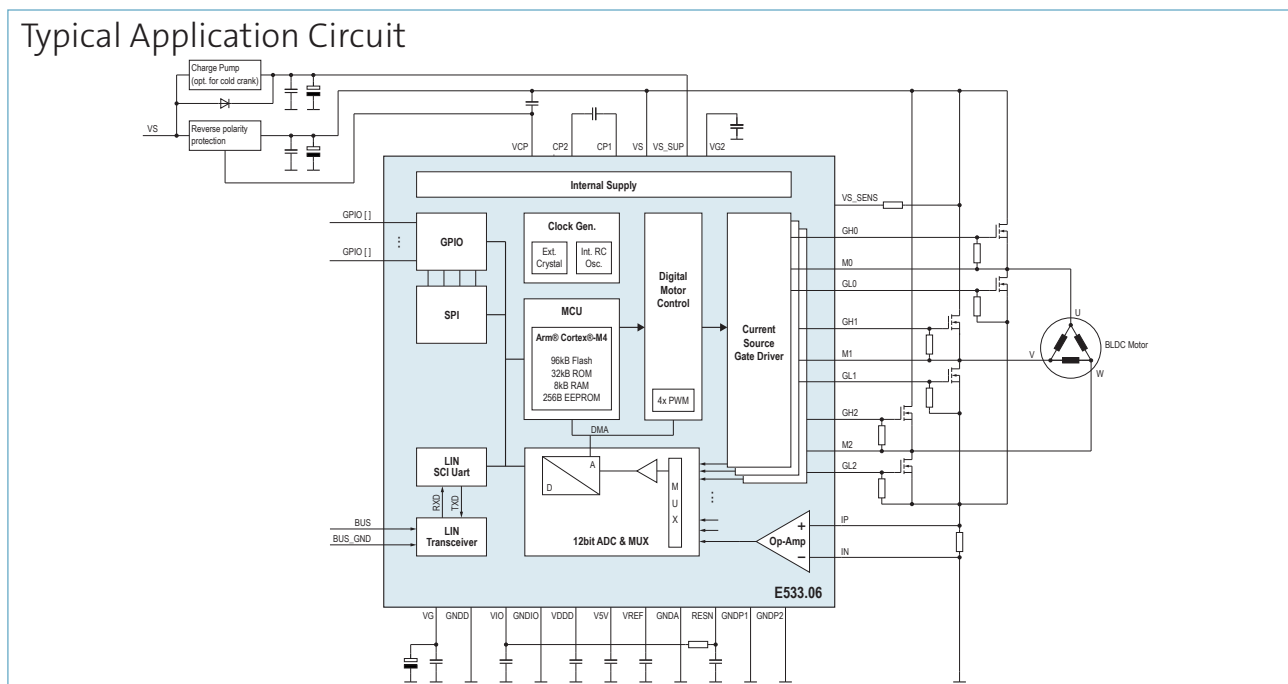

This document contains information on a product under development. Elmos Semiconductor SE reserves the right to change or discontinue this product without notice.

Elmos Support

Headquarters

Elmos Semiconductor SE
Heinrich-Hertz-Str. 1
44227 Dortmund (Germany)
Phone: +49 (0) 231 / 75 49-100
Fax: +49 (0) 231 / 75 49-149
sales-germany@elmos.com
www.elmos.com

Sales and Application Support Office North America

Elmos NA. Inc.
sales-usa@elmos.com

Sales and Application Support Office China

Elmos Semiconductor Technology (Shanghai) Co., Ltd.
sales-china@elmos.com

Sales and Application Support Office Korea

Elmos Korea
sales-korea@elmos.com

Sales and Application Support Office Japan

Elmos Japan K.K.
sales-japan@elmos.com

Sales and Application Support Office Singapore

Elmos Semiconductor Singapore Pte Ltd.
sales-singapore@elmos.com

Note: Elmos Semiconductor SE (below Elmos) reserves the right to make changes to the product contained in this publication without notice. Elmos assumes no responsibility for the use of any circuits described herein, conveys no licence under any patent or other right, and makes no representation that the circuits are free of patent infringement. While the information in this publication has been checked, no responsibility, however, is assumed for inaccuracies. Elmos does not recommend the use of any of its products in life support applications where the failure or malfunction of the product can reasonably be expected to cause failure of a life-support system or to significantly affect its safety or effectiveness. Products are not authorized for use in such applications.

Copyright © 2021 Elmos. Reproduction, in part or whole, without the prior written consent of Elmos, is prohibited.