

Power LIN2.X Stepper with Stall Detection

Production Data - Jan 28, 2016



Features

- For 1 bipolar stepper or up to 3 DC motors
- Motor currents up to 2* 800mA (peak)
- Programmable chopper current values for sinus or customized micro-stepping
- 5.5V - 20V supply voltage (load dump 42V)
- Very low sleep mode current, typ. 30µA
- 8bit µController with assistance logic and
 - 256 Byte RAM, boot-loader
 - 8kByte FLASH or ROM (opt. firmware)
 - 64 Byte EEPROM for customer parameters
- 3 * Hall-sensor/potentiometer inputs+supply
- LIN 2.x, SAE J2602 or bidirect. PWM-interface compatible to LIN2.2Rev.A, 2.2, 2.1, 2.0, 1.3
- QFN32L6 package

Added value factors

- Sensor less “stall detection”
- JTAG or LIN FLASH programming
- 40°C to +165°C peak junction temperature
- optional: LIN with Auto-Addressing (SNPD)

Applications

- Automotive Head-Light-Adjust
- Automotive Front-Grill-Shutter
- Automotive Water-Valves

General Description

This system-in-a-chip IC controls bipolar stepper actuators with current-choppered micro-stepping. The IC is controlled by a LIN2.x interface. It's LIN-address can be calculated by the “auto-addressing” feature (called “SNPD” in official LIN-specification). Alternatively the IC can be controlled by a PWM-interface, with diagnosis feedback. The integrated sensor-less “stall-detection” detects mechanical end-positions and stops the motor to reduce acoustical noise during initialization runs. The calculating heart is an 8-bit controller which is assisted by powerful circuitry. For absolute precise positioning, up to 3 Hall-sensors or potentiometers can read out.

The IC can also drive up to 3 DC motors or other loads. ICs with FLASH-memory are programmable via JTAG interface or LIN in normal or high speed mode. The IC is available with standard firmware as well as with a development system for individual firmware.

Ordering Information

Ordering-No.:	Features
E52330C77B	LIN or PWM-interface, LIN auto-addressing, 8k FLASH
E52331C77B	LIN with firmware (FLASH)
E52332A77B	LIN with firmware (ROM)
E52333A77B	LIN or PWM with 8k ROM
E52334C77B	PWM interface 8k FLASH
E52335C77B	PWM interface with firmware (FLASH)
E52336A77B	PWM interface with firmware (ROM)
E52337C77B	LIN or PWM with 8k FLASH
E52338A77B	LIN, auto-addressing, 8k ROM

Typical Application Circuit

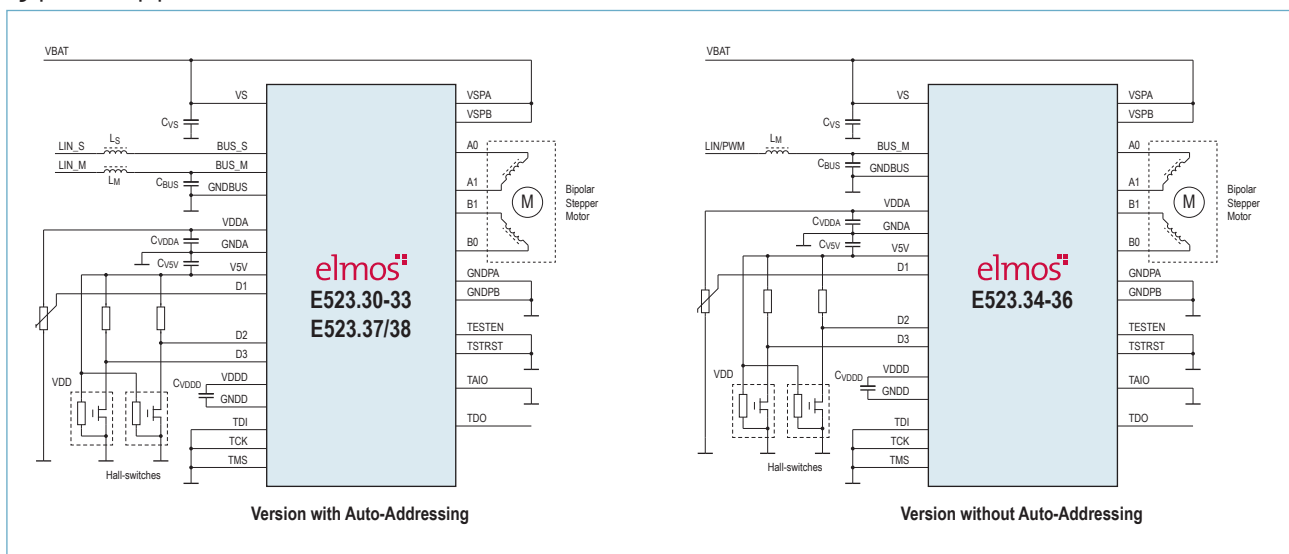

Elmos Semiconductor AG reserves the right to change the detail specifications as may be required to permit improvements in the design of its products.

Elmos Support

Headquarters

Elmos Semiconductor AG
Heinrich-Hertz-Str. 1
44227 Dortmund (Germany)
Phone: +49 (0) 231 / 75 49-100
Fax: +49 (0) 231 / 75 49-149
sales-germany@elmos.com
www.elmos.com

Sales and Application Support Office North America

Elmos NA. Inc.
32255 Northwestern Highway, Suite 220
Farmington Hills, MI 48334 (United States)
Phone: +1 (0) 248 / 8 65 32 00
Fax: +1 (0) 248 / 8 65 32 03
sales-usa@elmosna.com

Sales and Application Support Office China

Elmos Semiconductor Technology (Shanghai) Co., Ltd.
Unit 16B, 16F Zhao Feng World Trade Building,
No. 369 Jiang Su Road,
Chang Ning District,
Shanghai, PR China, 200050
Phone: +86 (0) 21 / 6210 0908
Fax: +86 (0) 21 / 6219 7502
sales-china@elmos.com

中国地区销售与应用支持

艾尔默斯半导体技术(上海)有限公司
中国 上海市 长宁区 江苏路369号
兆丰世贸大厦16楼 16B单元, 200050
电话: +86 (0) 21 / 6210 0908
传真: +86 (0) 21 / 6219 7502
sales-china@elmos.com

Sales and Application Support Office Korea

Elmos Korea
B-1007, U-Space 2, #670 Daewangpangyo-ro,
Sampyoung-dong, Bunddang-gu, Sungnam-si
Kyounggi-do 463-400 Korea
Phone: +82 (0)31 / 7 14 11 31
Fax: +82 (0)31 / 6 28 10 90
sales-korea@elmos.com

Sales and Application Support Office Japan

Elmos Japan K.K.
BR Shibaura N Bldg. 7F
3-20-9 Shibaura, Minato-ku,
Tokyo 108-0023 Japan
Phone: +81 3 / 3451-7101
Fax: +81 3 / 3451-7104
sales-japan@elmos.com

Sales and Application Support Office Singapore

Elmos Semiconductor Singapore Pte Ltd.
3A International Business Park
#09-13 ICON@IBP
609935 Singapore
Phone: +65 (0) 6908 1261
Fax: +65 (0) 6570 5906
sales-singapore@elmos.com

Note: Elmos Semiconductor AG (below Elmos) reserves the right to make changes to the product contained in this publication without notice. Elmos assumes no responsibility for the use of any circuits described herein, conveys no licence under any patent or other right, and makes no representation that the circuits are free of patent infringement. While the information in this publication has been checked, no responsibility, however, is assumed for inaccuracies. Elmos does not recommend the use of any of its products in life support applications where the failure or malfunction of the product can reasonably be expected to cause failure of a life-support system or to significantly affect its safety or effectiveness. Products are not authorized for use in such applications.

Copyright © 2016 Elmos. Reproduction, in part or whole, without the prior written consent of Elmos, is prohibited.